

# TALOS M50

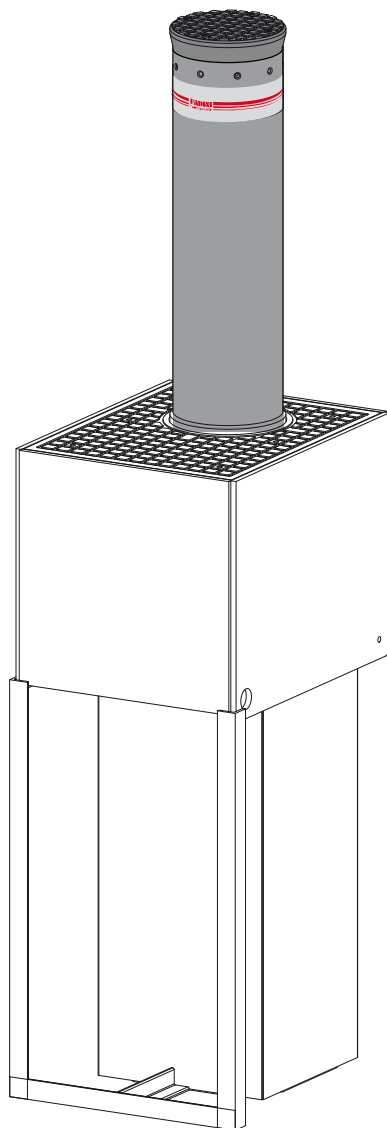

**Security bollard with fully retractable post. Certified and tested in compliance with:**

- ASTM F2656-15 C750 (former K12)
- PAS 68:2013 V/7500 (N3)/80
- IWA 14-1:2013 V/7200 [N3C]/80



EN 13241  
EN 12453  
EN 12445

Made in Italy

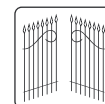

**FADINI**  
the gate opener

## GENERAL WARNINGS FOR PEOPLE SAFETY

### INTRODUCTION

This operator is designed for a specific scope of applications as indicated in this manual, including safety, control and signaling accessories as minimum required with **FADINI** equipment. □ Any applications not explicitly included in this manual may cause operation problems or damages to properties and people. □ Meccanica Fadini snc is not liable for damages caused by the incorrect use of the equipment, or for applications not included in this manual or for malfunctioning resulting from the use of materials or accessories not recommended by the manufacturer. □ The manufacturer reserves the right to make changes to its products without prior notice. □ All that is not explicitly indicated in this manual is to be considered not allowed.

### BEFORE INSTALLATION

Before commencing operator installation assess the suitability of the access, its general condition and the structure. □ Make sure that there is no risk of impact, crushing, shearing, conveying, cutting, entangling and lifting situations, which may prejudice people safety. □ Do not install near any source of heat and avoid contacts with flammable substances. □ Keep all the accessories able to turn on the operator (transmitters, proximity readers, key-switches, etc) out of the reach of the children. □ Transit through the access only with stationary operator. □ Do not allow children and/or people to stand in the proximity of a working operator. □ To ensure safety in the whole movement area of a gate it is advisable to install photocells, sensitive edges, magnetic loops and detectors. □ Use yellow-black strips or proper signals to identify dangerous spots. □ Before cleaning and maintenance operations, disconnect the appliance from the mains by switching off the master switch. □ If removing the actuator, do not cut the electric wires, but disconnect them from the terminal box by loosening the screws inside the junction box.

### INSTALLATION

All installation operations must be performed by a qualified technician, in observance of the Machinery Directive 2006/42/CE and safety regulations EN 12453 - EN 12445. □ Verify the presence of a thermal-magnetic circuit breaker 0,03 A - 230 V - 50 Hz upstream the installation. □ Use appropriate objects to test the correct functionality of the safety accessories, such as photocells, sensitive edges, etc. □ Carry out a risk analysis by means of appropriate instruments measuring the crushing and impact force of the main opening and closing edge in compliance with EN 12445. □ Identify the appropriate solution necessary to eliminate and reduce such risks. □ In case where the gate to automate is equipped with a pedestrian entrance, it is appropriate to prepare the system in such a way to prohibit the operation of the engine when the pedestrian entrance is used. □ Apply safety nameplates with CE marking on the gate warning about the presence of an automated installation. □ The installer must inform and instruct the end user about the proper use of the system by releasing him a technical dossier, including: layout and components of the installation, risk analysis, verification of safety accessories, verification of impact forces and reporting of residual risks.

### INFORMATION FOR END-USERS

The end-user is required to read carefully and to receive information concerning only the operation of the installation so that he becomes himself responsible for the correct use of it. □ The end-user shall establish a written maintenance contract with the installer/maintenance technician (on -call). □ Any maintenance operation must be done by qualified technicians. □ Keep these instructions carefully.

### WARNINGS FOR THE CORRECT OPERATION OF THE INSTALLATION

For optimum performance of system over time according to safety regulations, it is necessary to perform proper maintenance and monitoring of the entire installation: the automation, the electronic equipment and the cables connected to these. □ The entire installation must be carried out by qualified technical personnel, filling in the Maintenance Manual indicated in the Safety Regulation Book (to be requested or downloaded from the site [www.fadini.net/supporto/downloads](http://www.fadini.net/supporto/downloads)).

□ Operator: maintenance inspection at least every 6 months, while for the electronic equipment and safety systems an inspection at least once every month is required. □ The manufacturer, Meccanica Fadini snc, is not responsible for non-observance of good installation practice and incorrect maintenance of the installation.

### DISPOSAL OF MATERIAL

Dispose properly of the packaging materials such as cardboard, nylon, polystyrene etc. through specializing companies (after verification of the regulations in force at the place of installation in the field of waste disposal). Disposal of electrical and electronic materials: to remove and dispose through specializing companies, as per Directive 2012/19/UE.

Disposal of substances hazardous for the environment is prohibited.



### CE DECLARATION OF CONFORMITY of the manufacturer:

Meccanica Fadini snc (Via Mantova, 177/A - 37053 Cerea - VR - Italy) declares under its own responsibility that Talos M50 is in compliance with the Machinery Directive 2006/42/CE, moreover: it is to be sold and installed as a comprehensive "Automatic System", including the accessories and components as recommended by the Manufacturing Company. In observance of the current directives, any automatic system is to be regarded as a "machine". Therefore it is required that all the applicable safety norms be strictly complied with by the installation agents, who are also required to issue a Declaration of Conformity of their own. The manufacturing company is not liable for incorrect applications or misuse of its products that are declared to be produced in compliance with the following norms: EN 12445 & EN 12453 ie. analysis of the risk and actions to cure them, Low Voltage Directive 2014/35/UE, Electro-magnetic Compatibility Directive 2014/30/UE. In order to certify the product, the Manufacturer declares under own responsibility the compliance with the PRODUCT NORMS EN 13241-1.

Meccanica Fadini s.n.c.  
Director in charge



### GENERAL DESCRIPTION

Security bollard fitted with a post, that retracts completely flat with the road level, and an incorporated oil-hydraulic motor-pump. Suitable for heavy duty applications being certified and tested in compliance with:

- ASTM F2656-15 C750
- PAS 68:2013 V/7500 (N3)/80
- IWA 14-1:2013 V/7200 [N3C]/80

The bollard is designed and constructed to be able to stop vehicles weighing 7.500 kg, running at a speed of 80 km/h and to absorb at least 1.872.000 Joules of energy, in compliance with the ASTM F2656-15, PAS 68:2013 and IWA 14-1:2013 standards. This bollard is designed for the protection of special areas, such as: military bases, airports, embassies, consulates, banks, prisons, etc. and all those areas requiring a high level of security and perimeter protection.

The bollards is fitted with a post (cylinder) rising 1.000 mm from ground level, diameter 275 mm, thickness 20 mm. The post of the bollard (when in fully raised position) remains 50 cm (constraint) inside the enclosure and is supported by two reinforcement plates, the thickness of each is 15 and 30 mm respectively.

The post is made of S355J steel, the surface is cataphoresis treated and coated by polyester powder; the post of the bollard is well visible in any climate conditions, being fitted with an approved, back-reflecting band sticker and 9 LEDs flashing all around the top. The post head is completed with a rubber edge providing protection in case of accidental impacts with pedestrians, etc. The foundation casing is made of treated steel, hot dip galvanized, while the structure of the inner assembly of the bollard is cold dip galvanized.

It is fitted with two magnetic limit switches: one for the post in raised position and one for the post in lowered position. All the inner electrical connections (oil-hydraulic motor-pump, limit switches, LEDs and possible accessories) are factory pre-wired in a watertight junction box fitted with a quick disconnection connector for the power supply cable. The protection grade of the connector fitted to the junction box is IP 66. Available, on request, even IP 67 and explosion-proof.

The oil-hydraulic drive unit is made up of two pumps, each operated by a 230 Vac electric motor. Protection grade IP 67. They are located in the upper part of the foundation enclosure, outside of the post, and are easy to be accessed once the rectangular cover plate has been removed. High pressure tubes (300 bars) connect the oil-hydraulic drive unit to the actuator.

ELPRO S50 is a printed circuit control board powered with 230 Vac voltage, external to the bollard and housed in a plastic box made of polycarbonate. Connections between the bollard and the control board must be made by using a multipole cable type FG 70R 12x1,5 mm<sup>2</sup> up to 20 m maximum; beyond this distance, cable section must be adequate, according to the rules of good installation praxis.

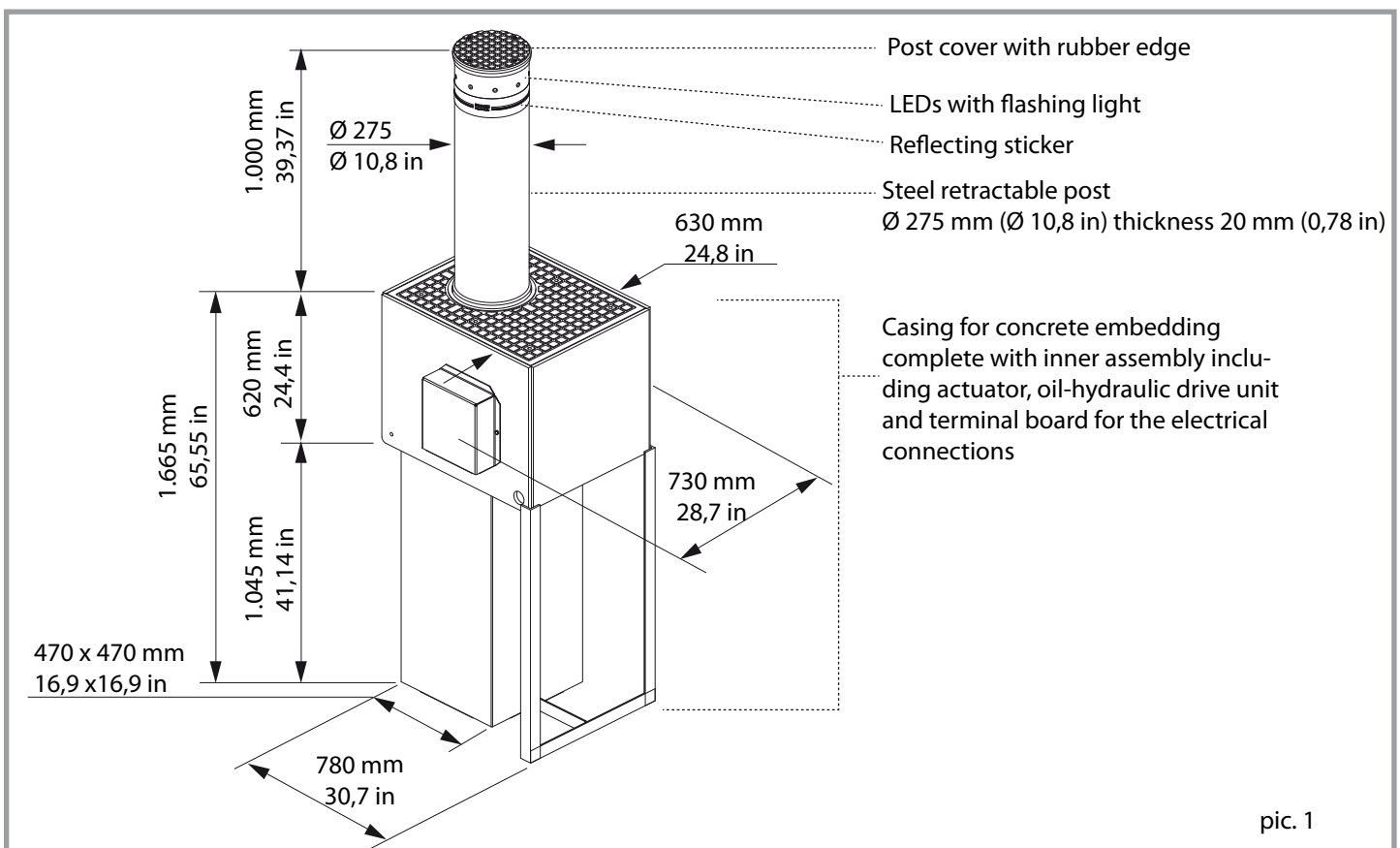

**EXCAVATION FOR POSITIONING OF THE CASING IN A CONCRETE FOUNDATION**

Dig a pit in the soil of about 4x3 m (157,8x118,1 in) and about 1,8 m (70,8 in) deep from the finished road level [A], as indicated in pic. 2.

Put a layer of pebbles in the bottom for rain water to soak away. Should rain water drainage be difficult in the bottom, create a smaller pit for water to gather in it and be pumped out of the bottom of the main pit by a submersed pump. Lay a Ø 50 mm (Ø 1,9 in) corrugated tube, suitable for the electric cables required to operate the bollard to be pulled through it.

English

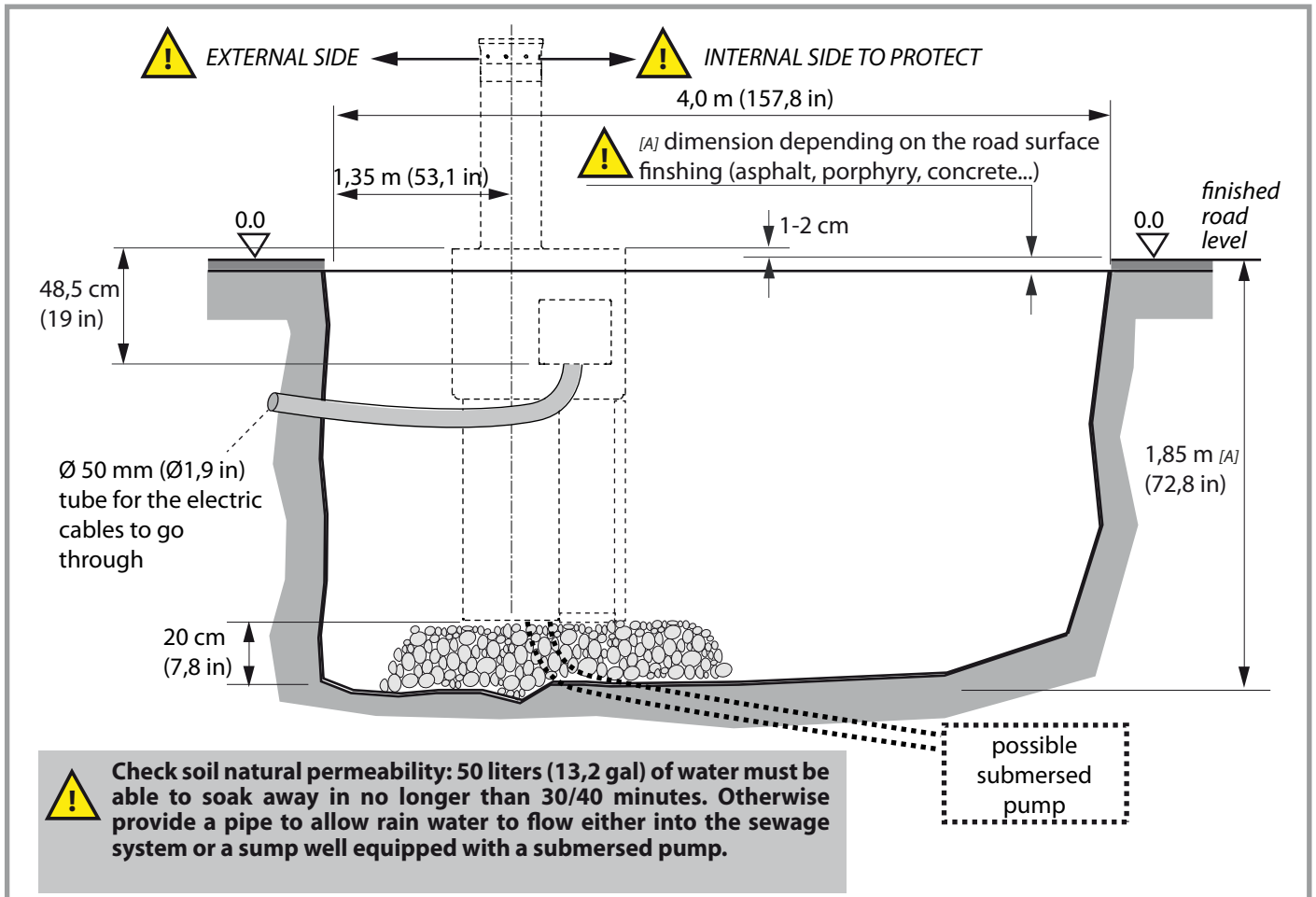

SECTIONAL VIEW

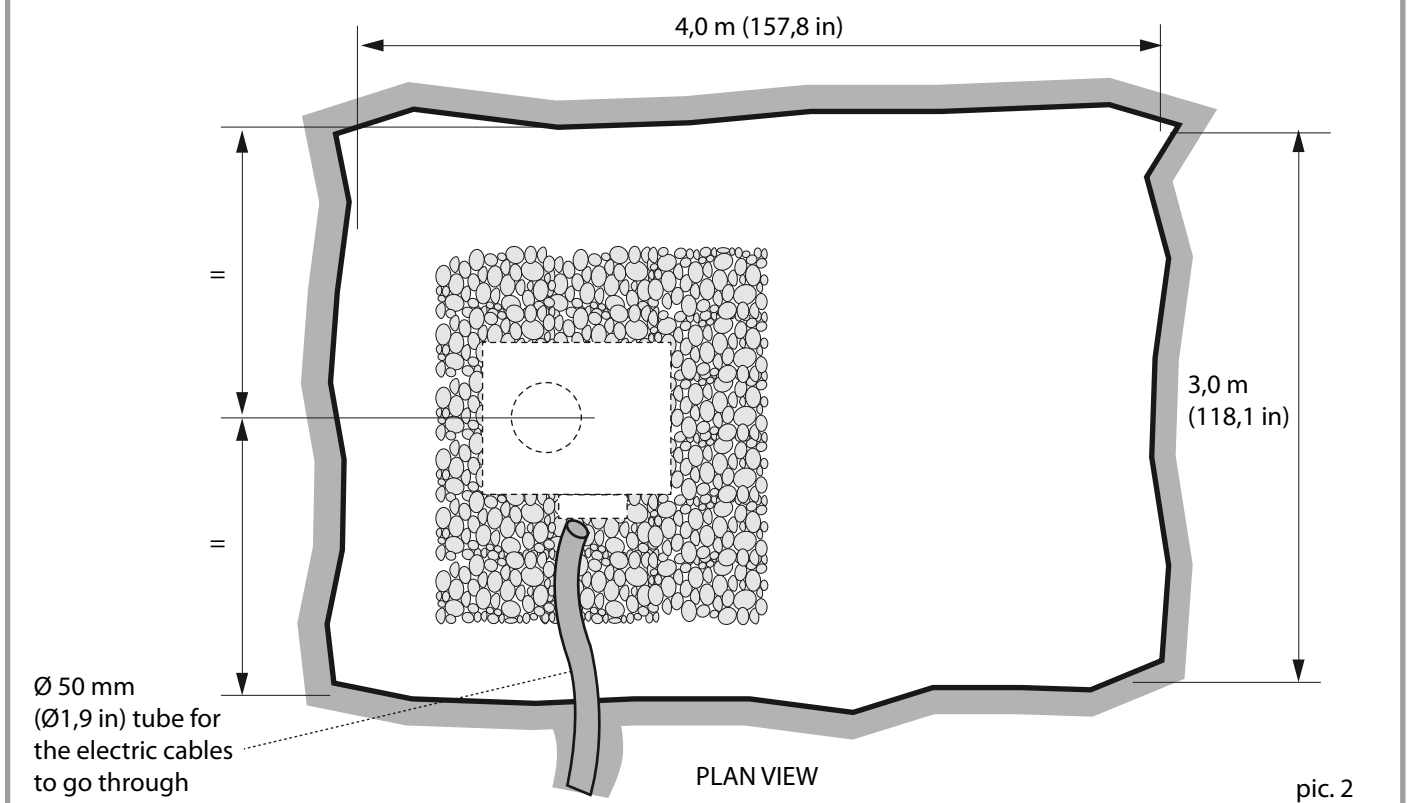

**POSSIBLE FUNCTIONING TEST (non mandatory for the installation)**  
**Talos M50 is factory-tested in all normal conditions of functioning, before being sent out to customer.**

Nevertheless, to allow that a few running tests to assess functioning are carried out before the installation, it is possible to access the inner terminal board with the electrical connections by removing the hatch cover: undo the two lateral screws of the cover and pull out the junction box with its connector.

Open the connector and carry out the electrical connections as illustrated in pic. 16 page 12.



**ATTENTION: Once the first running test is finished, fit back the junction box and close back the hatch.**

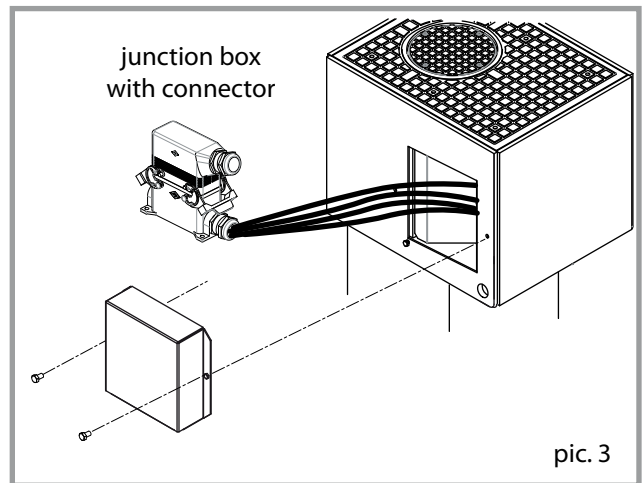

pic. 3

### INSERTING THE BOLLARD INTO ITS SEAT

Unscrew the six M12 screws that fix the cover plate and remove it by means of M16 supplied screws.

Remove the four x M18 screws and replace them with the four lifting rings allowing for the bollards to be hoisted.

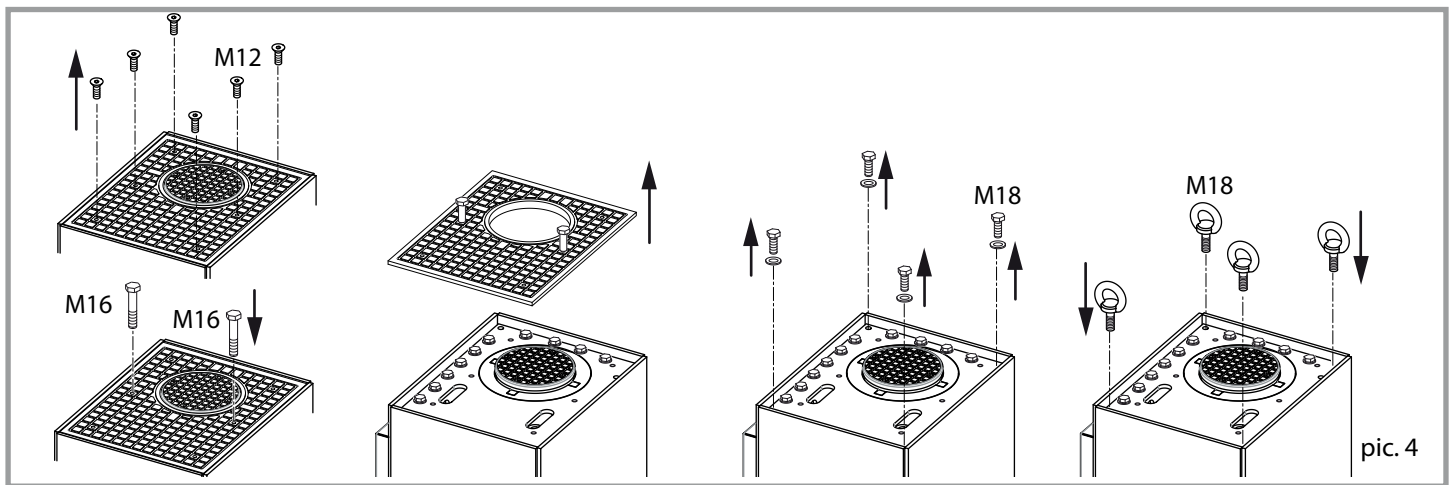

pic. 4

Position the bollard as indicated in the picture, and use a level to make sure it is in axis.

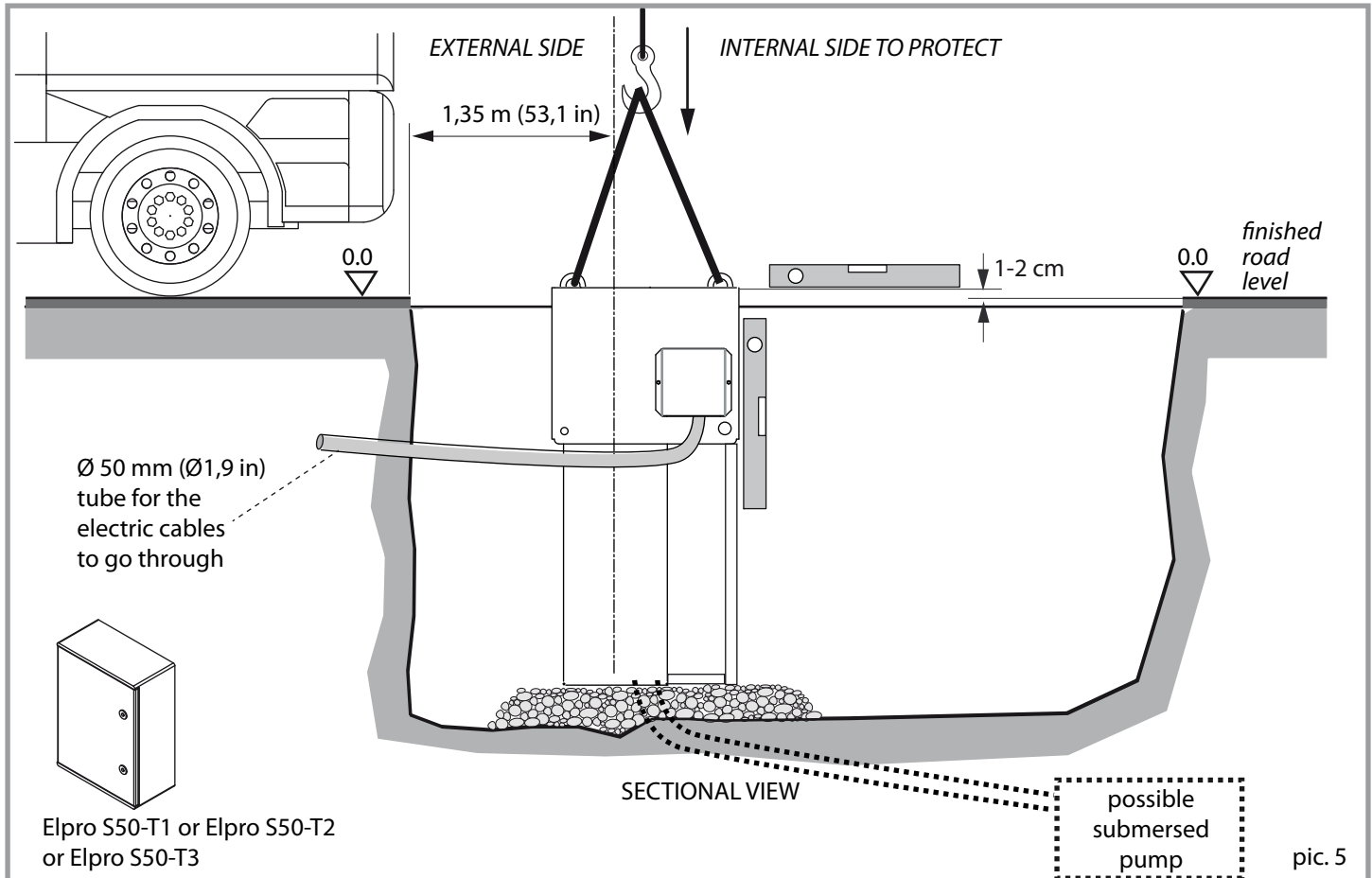

pic. 5

### CONSTRUCTION OF THE FOUNDATION CAGE TO CEMENT (not provided by the manufacturer)

The foundation cage is to be made on the installation site.

dimensions in millimeters (margin of tolerance of  $\pm 0,5$  cm - (1,9 in))

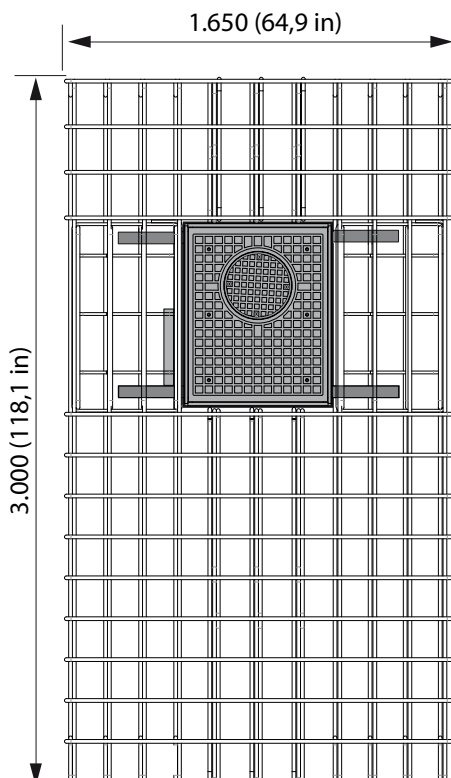
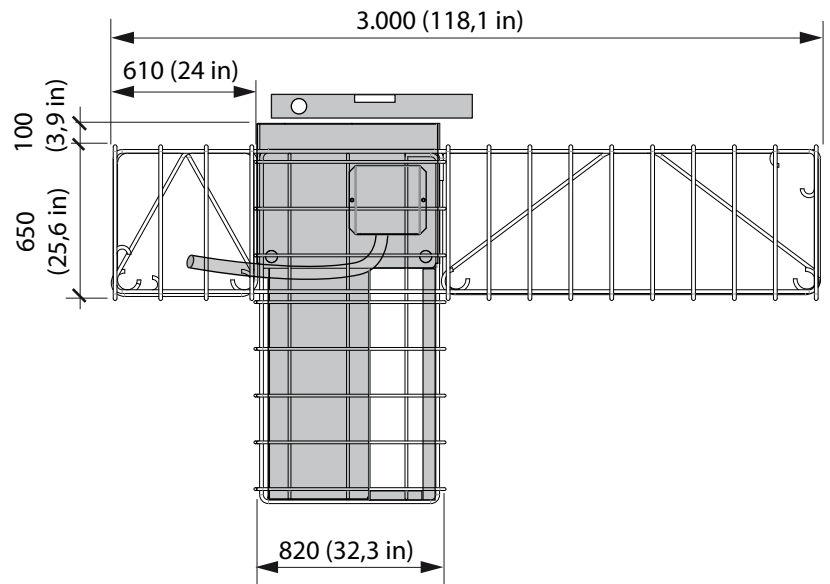
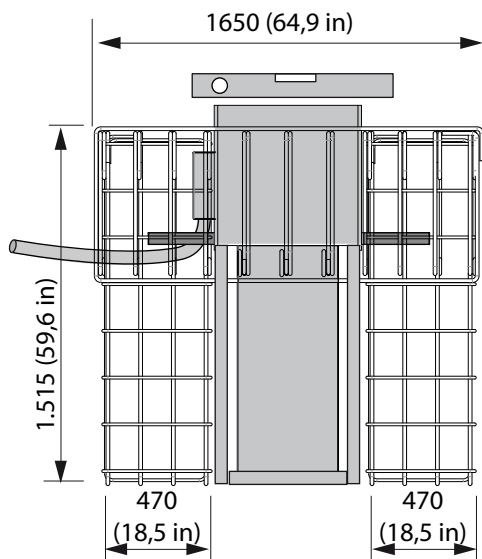

**TOTAL WEIGHT of iron grid: 350 kg**



The bollard is to be positioned and levelled on plane before casting concrete around the foundation cage



**The steel framework** is to be class B450C (ASTM A615 Grade 60) made of ribbed bars, yield point  $\geq 450$  MPa and breaking point  $\geq 540$  MPa



- Insert the roll-over bars into the holes in the ground casing (**internal side**), then fix them to the lateral cages, making sure that the bars come out from both sides in equal measure.
- Fix the roll-over bars into the holes in the ground casing with screws (**external side**).

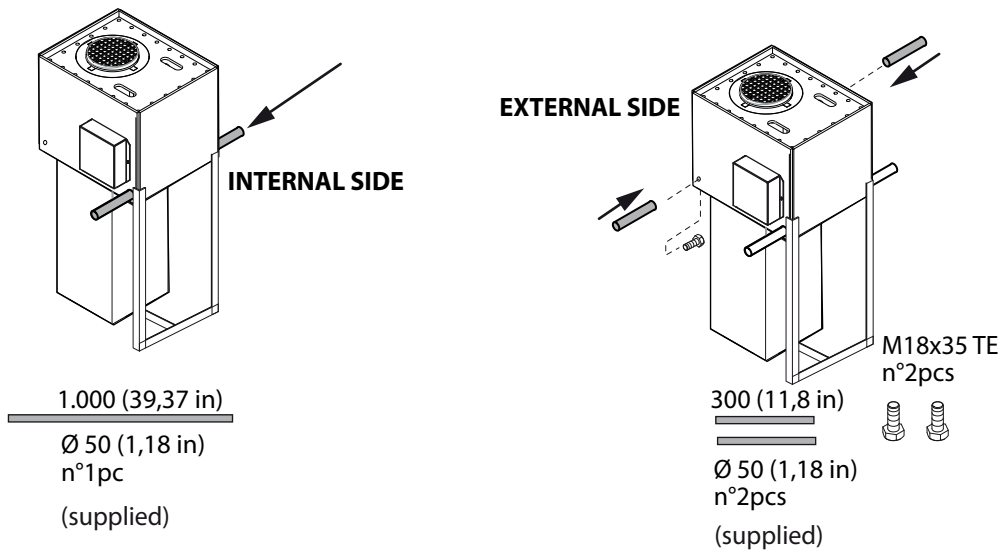

pic. 7



Joining of the cages and of the entire steel framework can be made by steel wire or welding

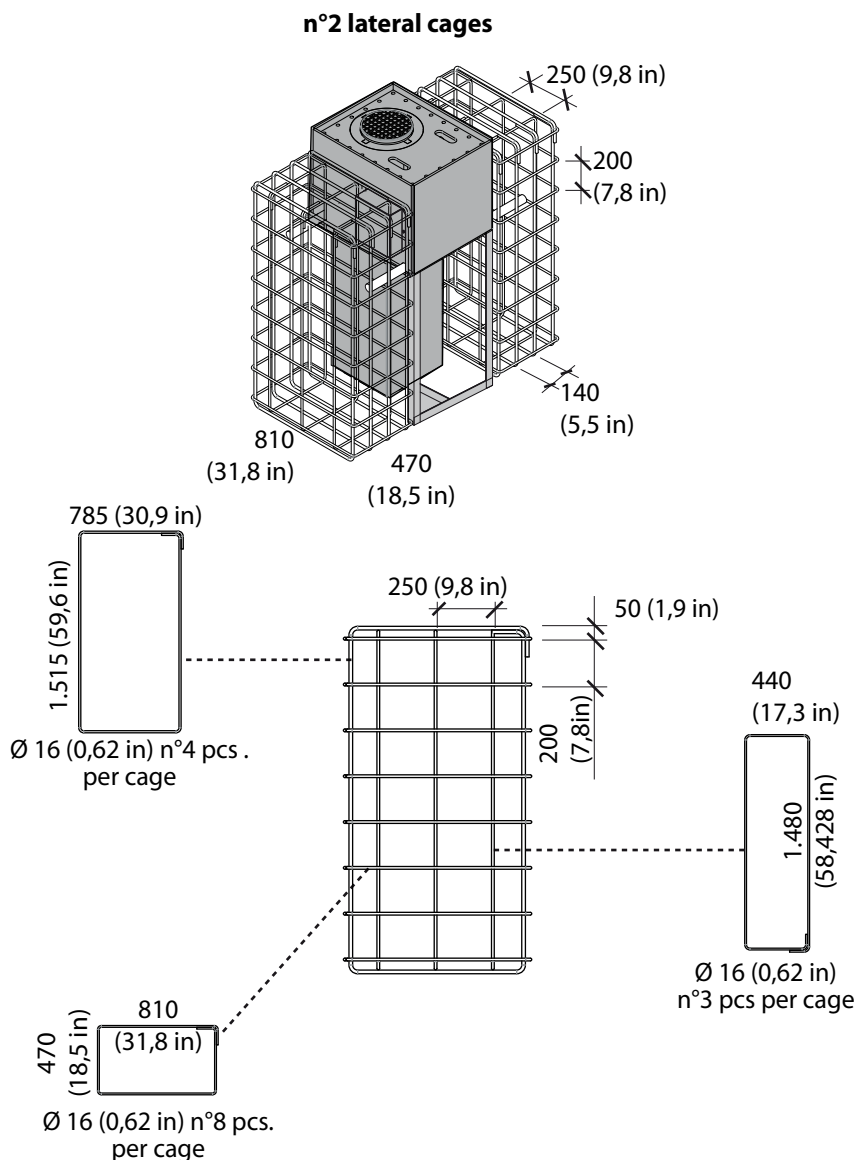

pic. 8



Joining of the cages and of the entire steel framework can be made by steel wire or welding

**nos. 8 Longitudinal rectangular rebar rings**

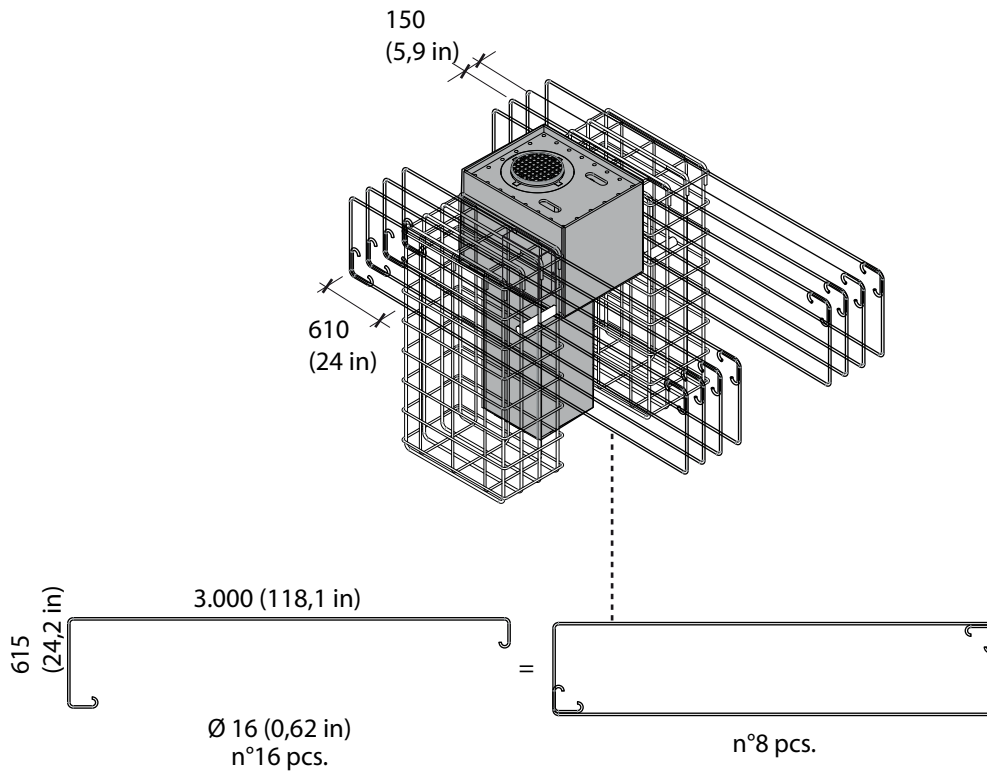

pic. 9



Joining of the cages and of the entire steel framework can be made by steel wire or welding

**nos.14 Transverse rectangular rebar rings**

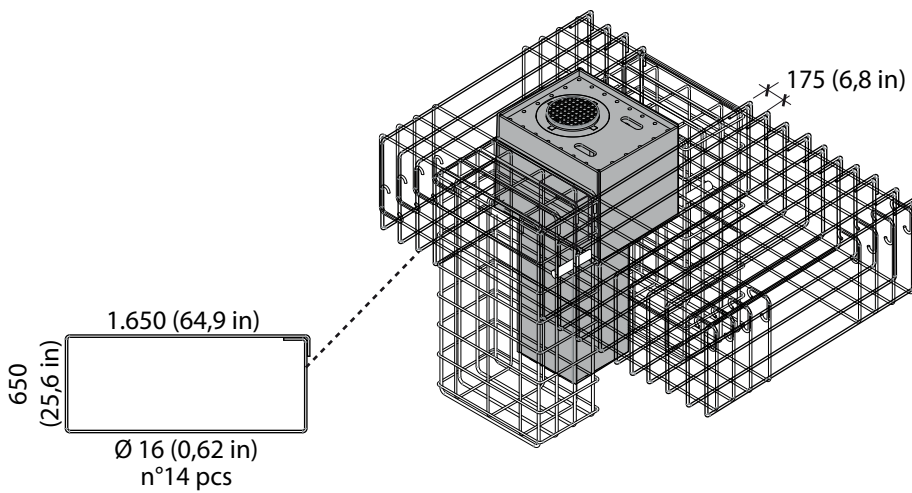

pic. 10





Joining of the cages and of the entire steel framework can be made by steel wire or welding

**nos. 3 Longitudinal rebars**

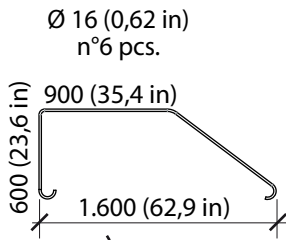

n°3 pcs.

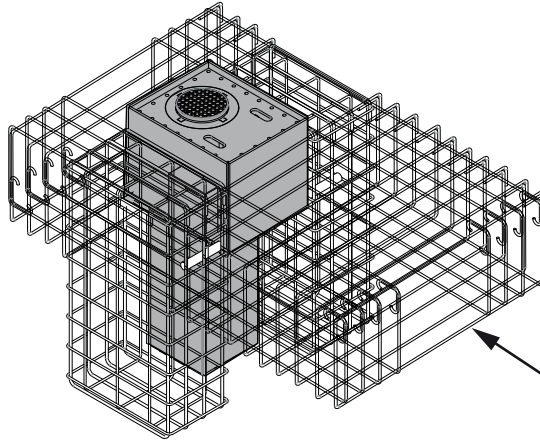
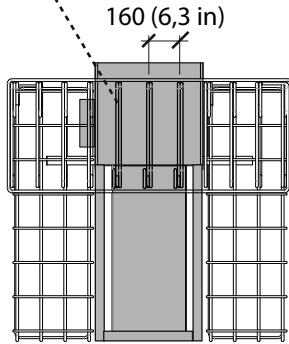
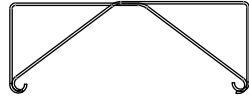

n°3 pcs.

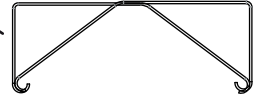

pic. 11



Joining of the cages and of the entire steel framework can be made by steel wire or welding

**nos. 3 Reinforcing bars to be tied at the base of the longitudinal rebars**

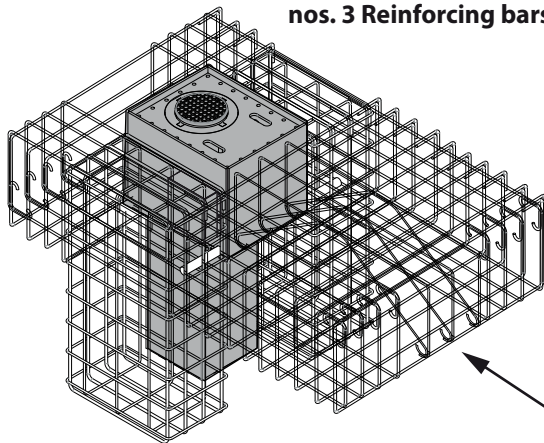

Ø 16 (0,62 in)  
n°3 pcs.

1.600 (62,9 in)

pic. 12



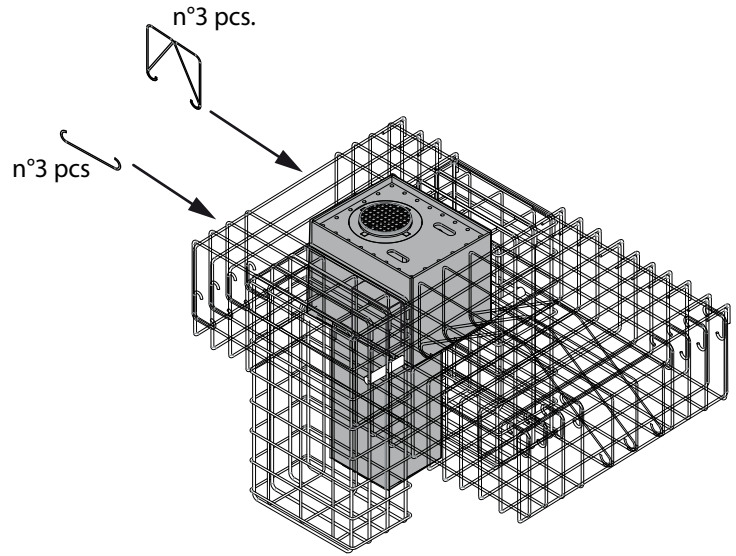
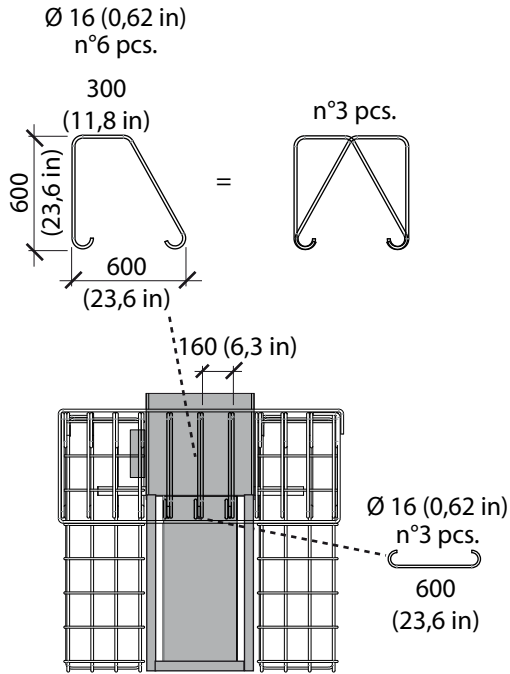

Joining of the cages and of the entire steel framework can be made by steel wire or welding

**n°3 Reinforcing bars for the external side**



pic.13

dimensions in millimeters (margin of tolerance of  $\pm 0,5$  cm - (1,9 in))

-  **Concrete features:**  
A - Class C25/30, 10-30 aggregates and Rck value  $\geq 30$  N/mm<sup>2</sup> according to UNI EN 12620
-  Concrete Volume: 6 m<sup>3</sup>
-  **Soil:** 90% compaction index, with "Proctor" optimal curve in compliance with UNI EN 13286-2:2005

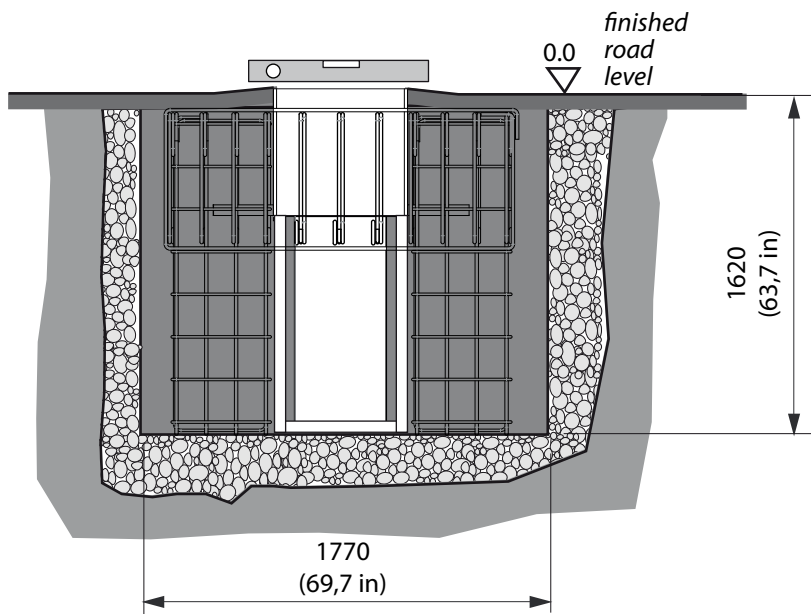
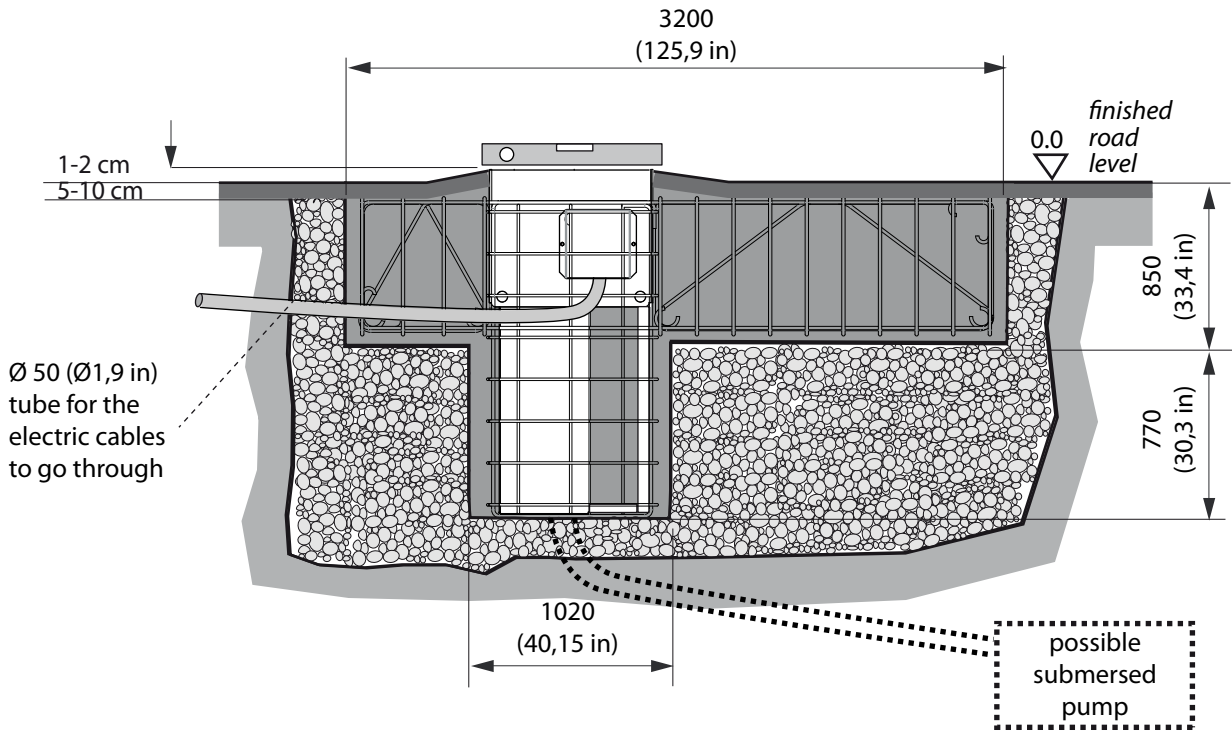

-  **Concrete casting:** let it set firmly for 7 days before carry on with the installation of the bollard

English

pic. 14

### OPENING THE PROTECTION COVER PLATE

Remove all the screws to be able to pull away the plate and then access the bollard inside for the electrical connections.

English

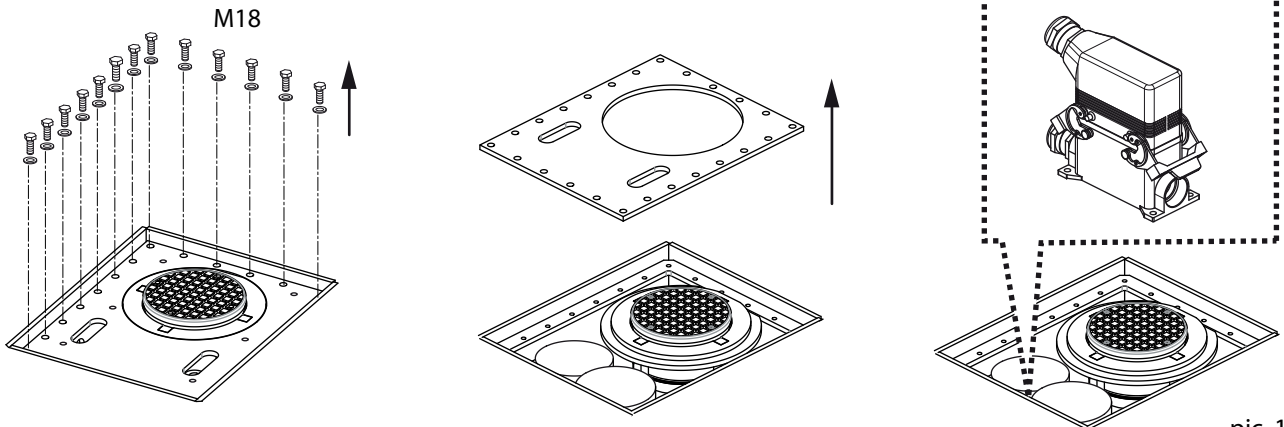

A watertight box is factory-fitted inside the bollard and pre-wired with all the required electrical connections to the bollard (electric motor, limit switches, LED lights).

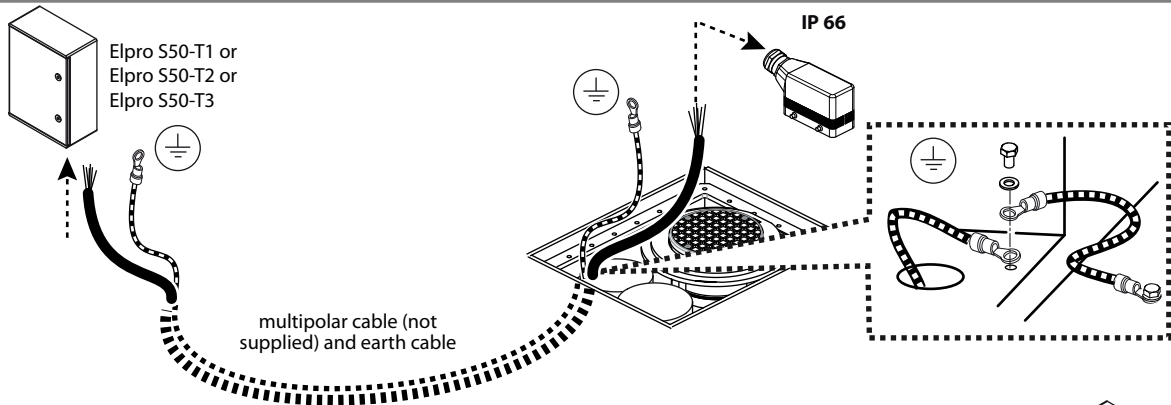

**⚠ Connections to the terminals of Elpro S50-T1 or Elpro S50-T2 or Elpro S50-T3 controllers (by cable type BUT FLESSIBILE FG 7OR 12x1,5 mm<sup>2</sup>) Earth cable size based on the characteristics of the place of installation.**

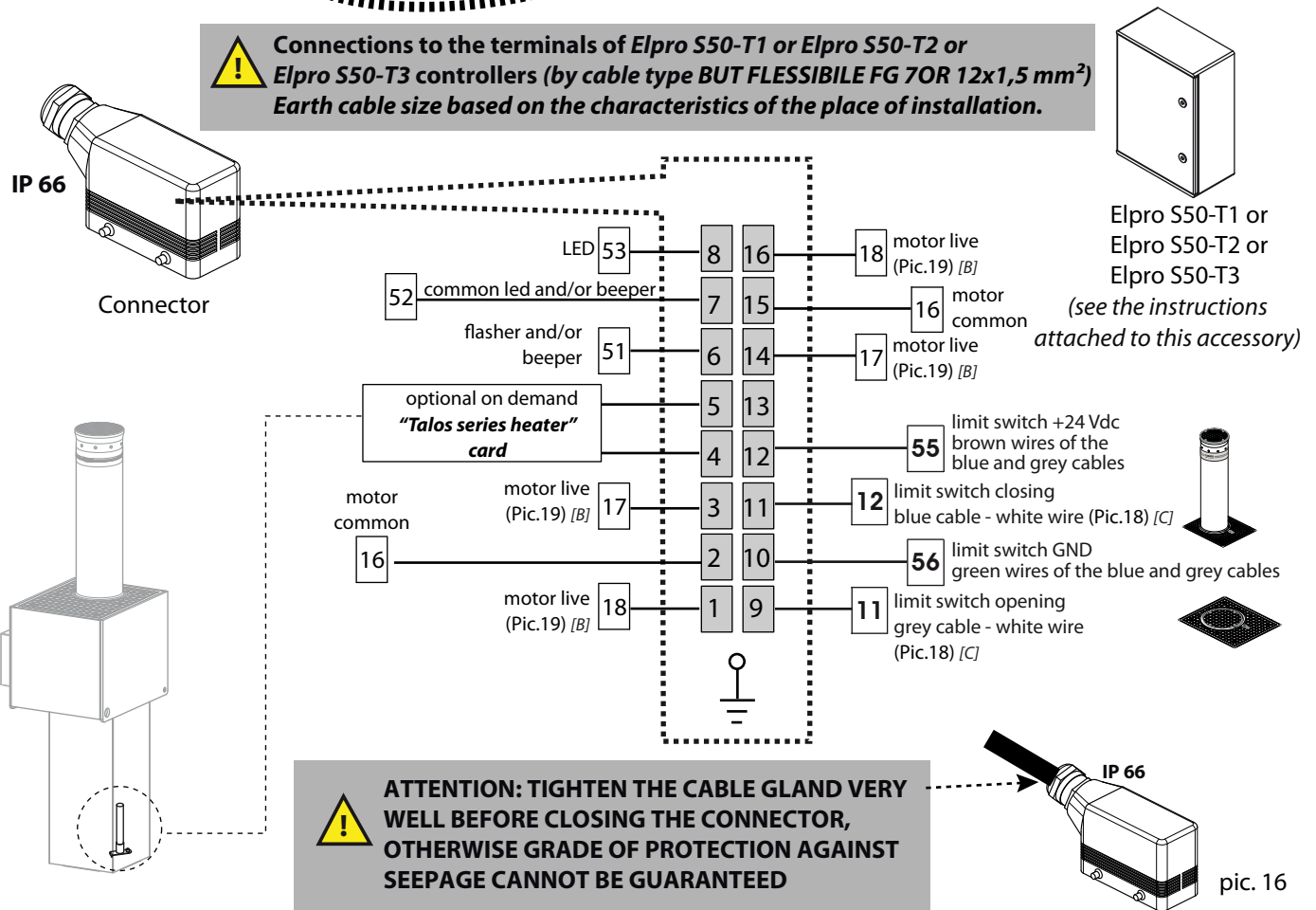

### FIRST RUNNING TESTS

**! ATTENTION: power supply the installation only after all the electrical connections have been completed.**

Once satisfied that all the safety (all NC contact to Elpro S50 controller must be closed) and command accessories have been connected, and the respective connections to the Elpro S50 controller made, the first running tests can be performed.

It is recommended that, before this phase, an accurate analysis of the risks be executed.

If a radio transmitter is available, after having match encoded it with the radio receiver following the provided instructions, pulse it once to raise the post.

**[C] Check the electrical connections to the limit switches. Once the system has been power supplied, check the LEDs status first of all: with the post in the lowered position L12 LED is OFF, while L13 LED is ON. If this does not happen, swap connections to terminals 11 and 12 on the Elpro S50 control board.**

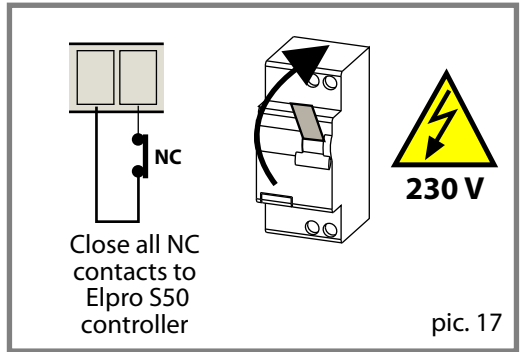

English

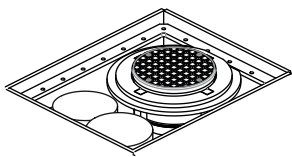

**! ATTENTION: the post must be fully down. If during the installation phase the post rises, even partially, operate the manual release to bring it fully down to end of stroke (page 15).**

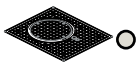
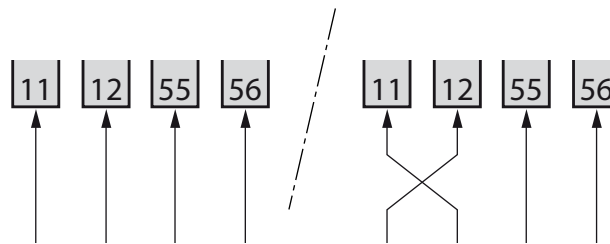

**L12 = Limit switch Opening M3, normally ON, it is off with post in down position**

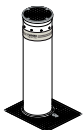

**L13 = Limit switch Closing M3, normally ON, it is off with post in up position**

pic. 18

**[B]** Once electric power is supplied, provided that the LEDs of the limit switches are correctly alight (post down L12 led OFF), by the first pulse the post should rise. If not, swap the connections to the motor live terminals (on Elpro S50) after having disconnected the electric power supply from the installation.

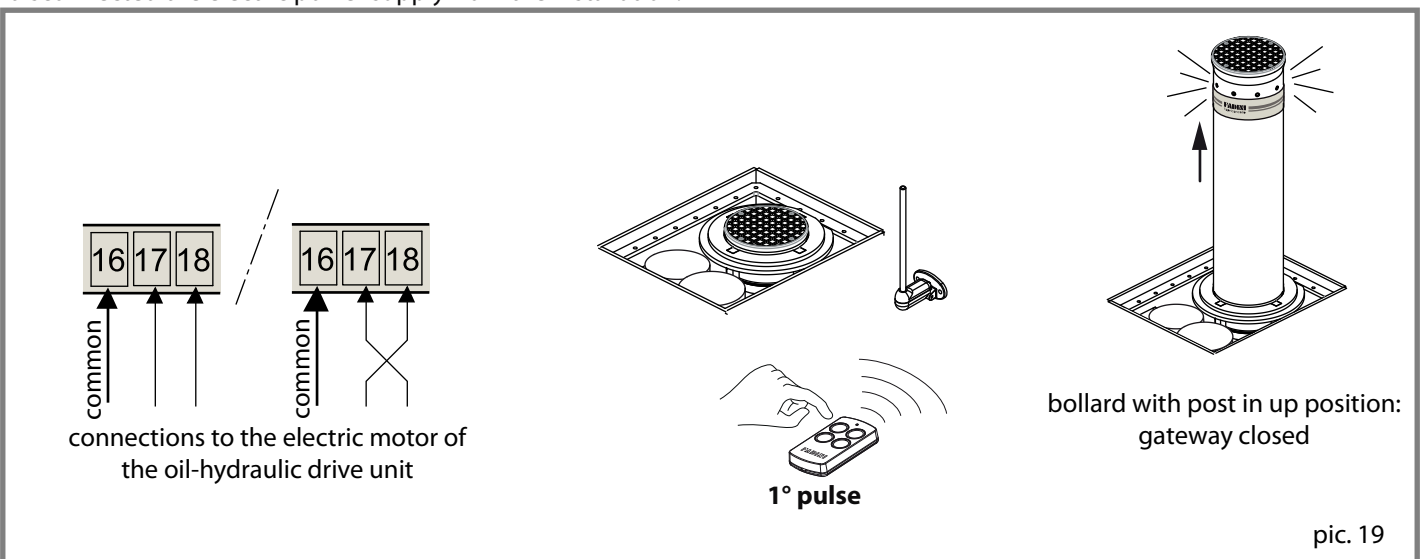

**FIXING THE BOLLARD TOP PLATES**

English

The protection plate must seat perfectly onto the entire surface, and adhere also to the circular flange all around the post

**NOTE WELL: THE BOLLARD POST AND THE PROTECTION PLATE MUST BE PERFECTLY CENTERED, SO THAT THE GAP BETWEEN THE POST AND PLATE IS UNIFORM ALL AROUND**

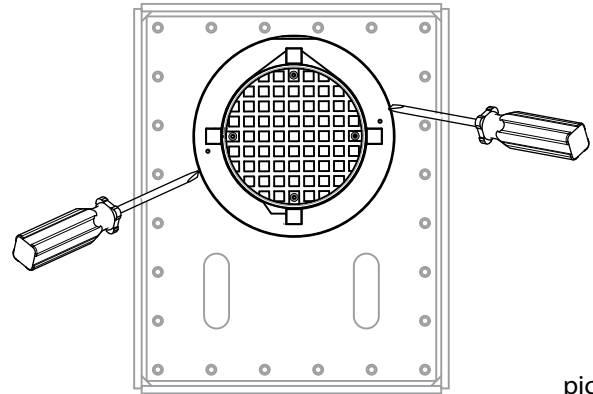
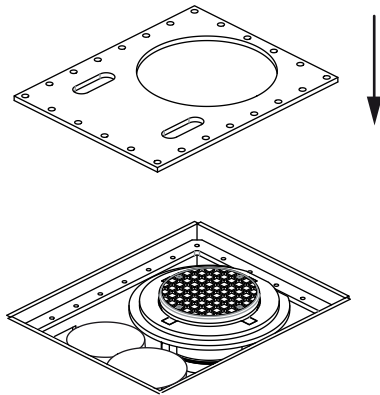

pic. 20

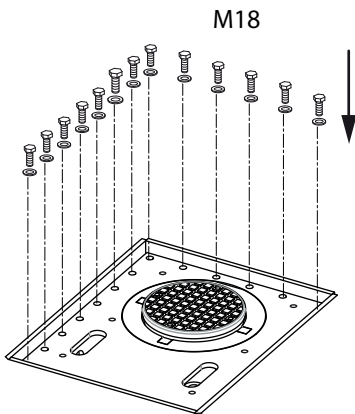

**NOTE WELL: IT IS RECOMMENDED THAT ALL THE FIXING SCREWS BE LUBRICATED BY GREASE**

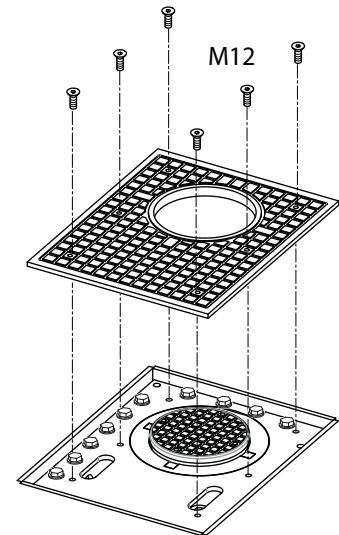

pic. 21

**RELEASE OPERATIONS FOR THE MANUAL LOWERING OF THE POST (IN CASE OF AN EMERGENCY)**

In case of power failure or disconnection the bollard is designed to keep the post in the up position.

It is possible, in particular situations of danger and/or emergency, to lower the post manually. The following operations are to be carried out:

Pull away the aluminium cover plate, after having removed all the fixing screws.

Insert the release spanner in the slit on the right, into the release device having a triangular profile: turn once anticlockwise.

**IMPORTANT: with the post in fully down position tighten hard clockwise by the release spanner.**

English

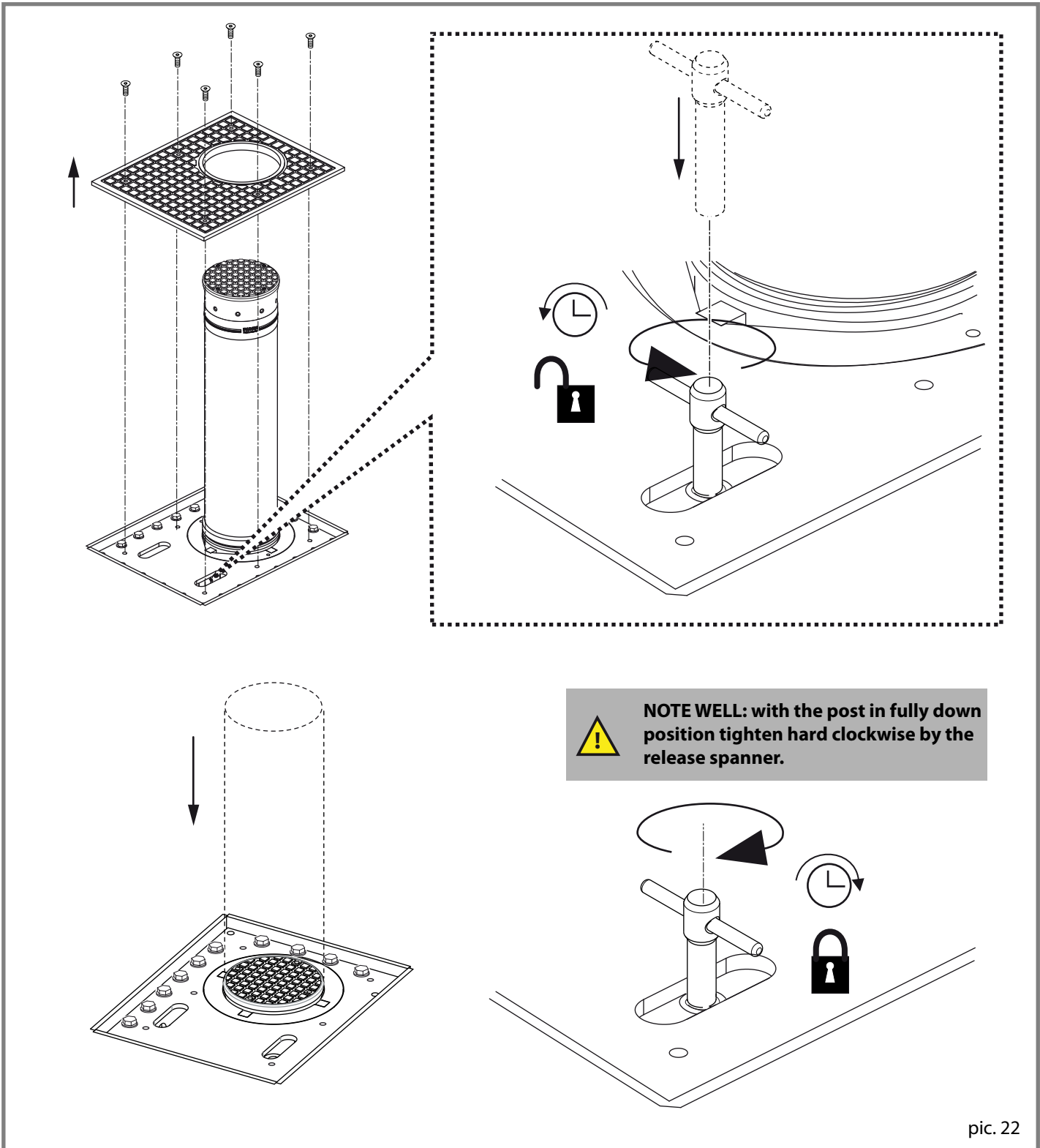

pic. 22

**MAINTENANCE RECORD**  
hand over to the end user of the installation



Installation address:		Maintainer:	Date:
Installation type: Sliding gate <input type="checkbox"/> Folding door <input type="checkbox"/> Swinging gate <input type="checkbox"/> Road barrier <input type="checkbox"/> Over-head door <input type="checkbox"/> <b>Bollard</b> <input checked="" type="checkbox"/> Lateral folding door <input type="checkbox"/> ..... <input type="checkbox"/>		Operator model:	Quantity of models installed:
		Dimensions per gate leaf:	
		Weight per gate leaf:	Installation date:

**NOTE WELL:** this document must record any ordinary and extraordinary services including installation, maintenance, repairs and replacements to be made only by using Fadini original spare parts. This document, for the data included in it, must be made available to authorized inspectors/officers, and a copy of it must be handed over the end user/s.

The installer/maintainer are liable for the functionalities and safety features of the installation only if maintenance is carried on by qualified technical people appointed by themselves and agreed upon with the end user/s.

N°	Service date	Service description	Technical maintainer	End user/s
1				
2				
3				
4				
5				
6				

\_\_\_\_\_  
Stamp and signature  
installation technician/maintainer

\_\_\_\_\_  
Signed for acceptance  
end user  
buyer

give to the end-user of the installation





**OPERATIONS FOR ORDINARY ROUTINE MAINTENANCE OF FADINI AUTOMATIC BOLLARDS (EVERY SIX MONTHS)**

The standard maintenance routine sequence is as follows:

- Clean the ground cylinder and suck all material settlements.
- Clean water drains located at the bottom of the ground cylinder and/or excavation pit.
- Check any possible oil leaking from the hydraulic piston and, in case, fix it.
- Overhaul the screws fastening the bollard to the ground cylinder, making sure they are properly tightened and lubricated.
- Check the oil-hydraulic motor-pump and oil pressure by assessing the rising times of the bollard. If required, top up oil in the reservoir and/or parallel add an extra capacitor to the existing one (instructions manual is to be referred to).
- Check the correct functioning of the signal LED lights (if incorporated) in the bollard head.
- Sight check the electronic board controlling the bollard/s (e.g.: "flooded" relay contacts, oxidized terminal clamps, etc.).
- Check the correct functioning and positioning of the limit switches.
- Check the release system for bollard manual operations.
- Clean and recondition the rising cylinder if required, e.g.: paint patching up, replacing the back reflecting sticker and /or the cover fitted with rubber edge.

**IF OPTIONAL ACCESSORIES ARE INCLUDED, FURTHER MAINTENANCE IS REQUIRED AS FOLLOWS:**

- Check the correct functioning of the safety accessories such as the inductive loop/s and the photocells.
- Check the correct functioning of the radio receiver and all of the remote controls.
- Check the correct functioning of the pressure switch.
- Check the correct functioning of the beeper.
- Check the correct functioning of the traffic lights and the respective control card.
- Check the correct functioning of the solenoid valve in emergency cases such as power failure or disconnection, assess therefore the status of the 24 Vdc voltage stabilizer.
- Check the correct functioning of EAR 35 acoustic analyzer to lower the bollard in emergency.



This symbol indicates that a particular attention is required on the installation phases and on running the operator. Failure to observe these indications may cause incorrect functioning of the bollard.



### INFORMATION ABOUT SAFETY AND PROPER FUNCTIONING OF THE SYSTEM



- 1) Installation operations, testing, analysis of the risks and future maintenance are to be executed by qualified and authorized technicians in compliance with the existing regulations ([www.fadini.net/supporto/download](http://www.fadini.net/supporto/download)).
- 2) This automatic system is intended to be exclusively used for the applications described in this manual, including at least the minimum safety, command and signalling accessories as required.
- 3) Any application not indicated in this manual may cause malfunctioning or damages to people and properties.
- 4) Providing a suitable reinforcement metallic framework ensures that the breakout resistance value be respected as stated in this manual. **NOTE:** the iron framework (all of the steel rebars) is not supplied by our company. It has to be made locally in compliance with the technical data, drawings and all of the indications described in this installation manual. The components of the structure developed in this way are able to make the most of the performance features of each component and ensure the impact resistance features of the bollard as indicated.
- 5) Make sure the soil is adequate to take the bollard to avoid that settling at a later stage causes problems to the system.
- 6) Make sure the site is free from utilities that may interfere with the installation.
- 7) Make sure that electromagnetic sources are at a suitable distance from the accessories, especially from the loop detectors. The magnetic fields of other sources may affect the detection of the loops as well as those of other command and safety devices of the system.
- 8) Make sure the power supply to the electric motor is 230 V (50 Hz).
- 9) **Recommended power supply cable: BUT FLESSIBILE FG 7OR 12x1,5 mm<sup>2</sup> up to 20 metres max.**

**Ground cable to have a section as required to comply with the site regulations.**

- 10) In case any components or accessories need replacing, use only original parts as provided by the manufacturer.
- 11) The installer shall provide the final user with information related to all of the operating commands and functions of the system, including that concerning lowering of the post in case of an emergency (manual release operation).
- 12) The installer shall inform the final user of the dangers coming from the presence of persons, especially children, in the proximity of the bollard.
- 13) The manufacturer reserves the right to change this manual without previous notice.

**As far as configuration and execution of the system are concerned, these are to comply with the laws in the country of installation.**



Meccanica Fadini is not liable for any possible damages derived from incorrect use or from any use not indicated in this manual, furthermore it is not answerable for malfunctioning caused by the use of materials or accessories not approved by the company itself.

It is to be noted that the product respects the impact and breakout resistance values as indicated provided that the installation of the same is carried out in observance of the specifications included in this manual of instructions. Various factors are to be carefully taken into consideration such as compaction index, soil permeability coefficient, concrete type, which may affect the indicated values even significantly.

### PRODUCT SPECIFICATIONS

Fully retractable automatic bollard for very heavy duty applications, certified and tested according to ASTM F2656-15 C750, PAS 68:2013 V/7500 (N3)/80 standards and IWA 14-1:2013 V/7200 [N3C]/80 standards; made up of two oil-hydraulic motor pump units incorporated in the structure and one oil-hydraulic actuator inside the rising cylinder. Designed to stop a vehicle of 7,5 t at a speed of 80 km/h and remain perfectly intact and operative for the protection of sites under risk of attack and all those areas where a high level of security and perimeter protection are required in case of a terrorist assault. IP67. The height of the rising cylinder (from ground) is 1.000 mm. Rising cylinder made of S355K2H steel, thickness 20 mm, cathaphoresis treated and powder coated. AISI 304 brushed stainless steel cover sleeve available for the rising cylinder. Rubber ring on rising cylinder head. Cathaphoresis treated aluminium cover, finished to provide a slip-proof treading surface. Rising cylinder fitted with high intensity, microprismatic, retroreflecting approved sticker (h 80 mm), and 9 signalling LEDs with flashing light all around the top. Hot dip galvanized steel casing for ground foundation. Impact resistance 700.000 J, breakout resistance 2.000.000 J. static load max 2.800 kg in standing position, max 20.000 kg in lowered position. Working temperature -40 °C +80 °C. Supply voltage 230 Vac ± 10%, 50 Hz. Absorbed power 3.100 W. Connector and junction box IP 66 for cabling. Rising time ~ 5,0 s. Frequency of use 2.000 cycles/day. Hydraulic device locking the bollard in standing position.

### TECHNICAL DATA

#### BOLLARD

Post diameter	Ø 275 mm
Post thickness	20 mm
Post height	1.000 mm
Post finish	polyester powder coating
Piston diameter	40 mm
Shaft diameter	30 mm
Actual shaft travel	1.010 mm
Frequency of use	very intensive (2.000 cycles/day)
Led power feeder	in: 230 V - 50 Hz out: 12 Vdc 600 mA
Led lights	12 Vdc
Post material	S355K2H steel

Impact resistance	700.000 J
Crash resistance	2.000.000 J
Maximun static load	20.000 kg
Weight complete with casing	770 kg
Environment working temperature	-20 °C +80 °C
Environment working temperature with heater	-40 °C +80 °C
Rising speed	20 cm/s (~ 5,0 s)
Lowering speed	31 cm/s (~ 3,2 s)

#### ELECTRIC MOTOR

Absorbed power	3.100 W (1.550 + 1.550)
Voltage supply	230 V
Frequency	50 Hz
Rated current	10 ÷ 13 A
Maximum current	15 A
Intermittent service	S3
Capacitor	80 µF
Starting capacitor	40 µF
Motor rotation speed	2.800 rpm

#### OIL-HYDRAULIC DRIVE UNIT TUNIT 9.20LP

Pump type	P20 + P20
Working pressure	2 MPa (20 bar)
Working temperature	-20 °C +80 °C
Oil type	Fadini Oil - code 708L
Oil reservoir	4,5 liters + 4,5 liters
Protection grade	IP 67

